

The Gala Floor Plans

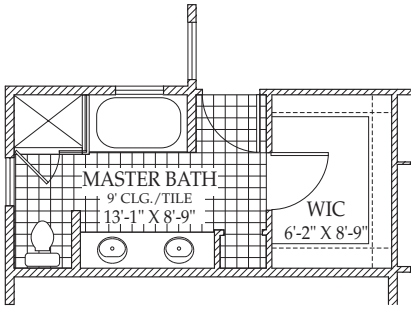

Harvest Hill
at The Orchard at New Market



OPTIONAL MASTER BATH

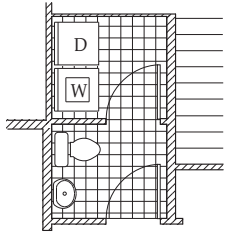

OPTIONAL POWDER ROOM

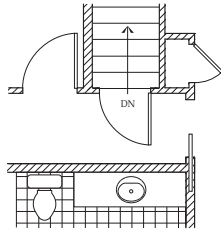

STAIRS TO OPTIONAL BASEMENT

MAIN LEVEL FLOOR PLAN

Dimensions are measured "inside-to-inside" and are approximate.

Front window pattern for elevation R-1.
See architectural plans for floor coverings
and for front window pattern associated with
other elevation alternatives.

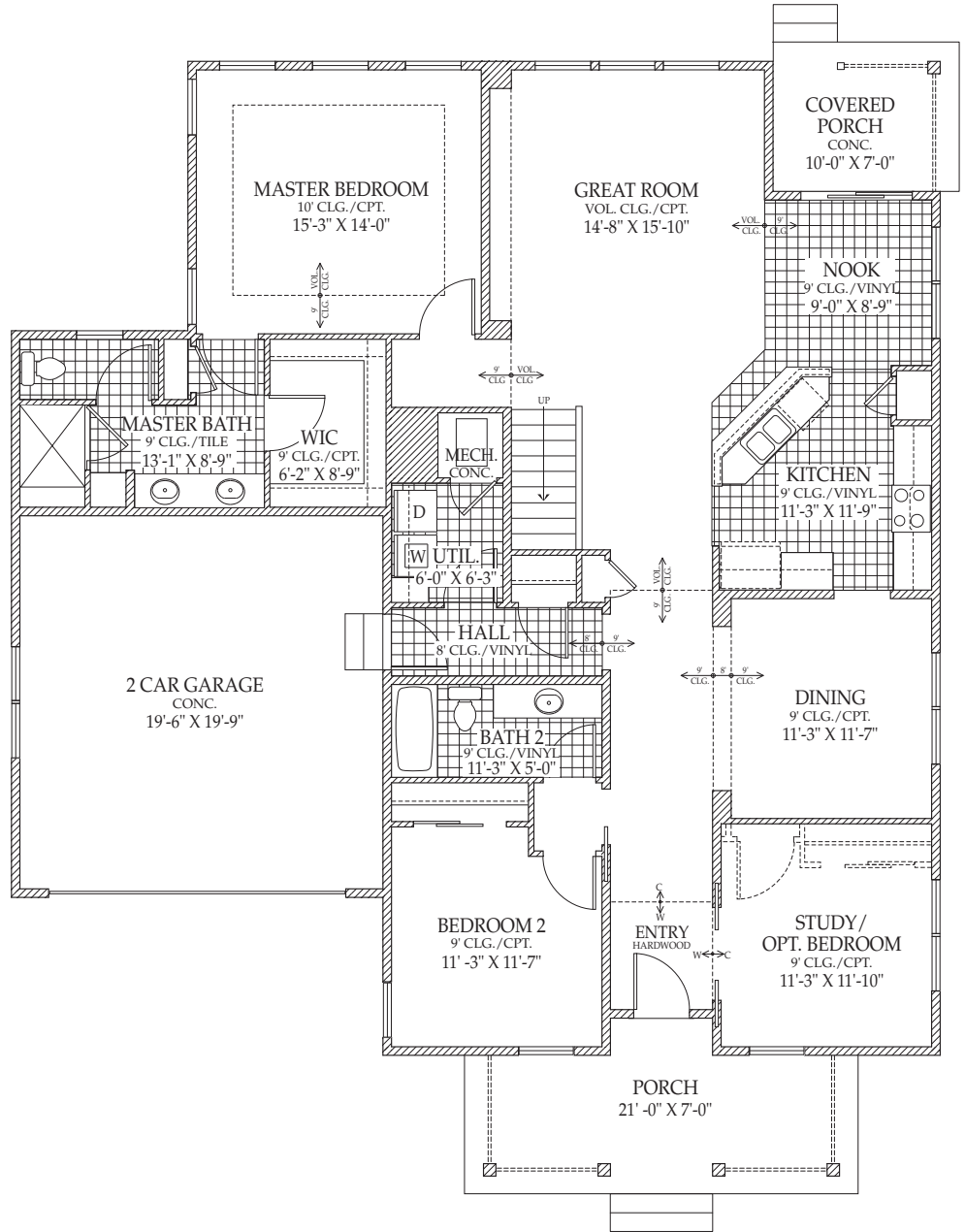

OPTIONAL ELEVATION 2

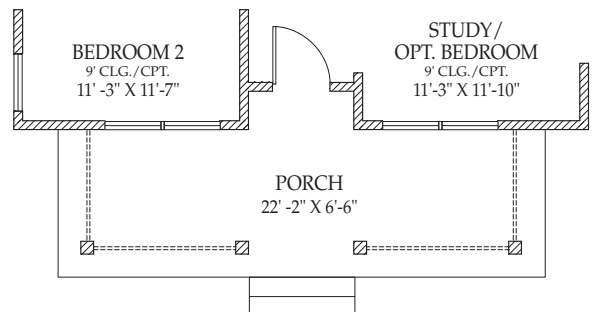

OPTIONAL ELEVATION 2



©2009 The Orchard at New Market, LLC and Seawright Homes, LLC
All dimensions are approximate and may vary subject to field
conditions. Room dimensions shown are interior dimensions.

The Gala Floor Plans



Harvest Hill
at The Orchard at New Market

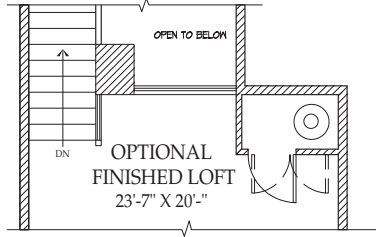

OPTIONAL LOFT

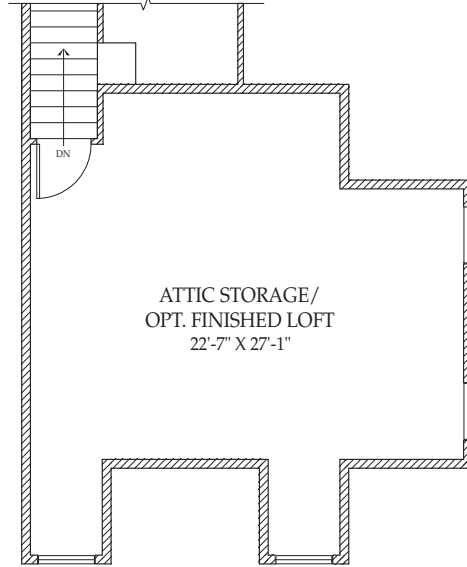

UPPER LEVEL PLAN 1

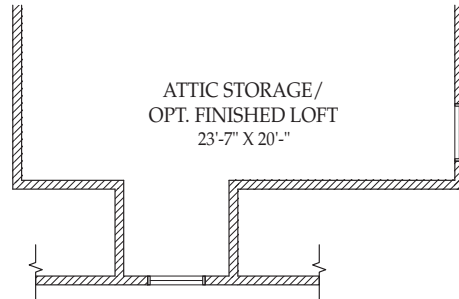

UPPER LEVEL PLAN 2

UPPER LEVEL FLOOR PLAN

Dimensions are measured "inside-to-inside" and are approximate.



©2009 The Orchard at New Market, LLC and Seawright Homes, LLC
All dimensions are approximate and may vary subject to field conditions. Room dimensions shown are interior dimensions.

Front window pattern for elevation R-1.
See architectural plans for floor coverings
and for front window pattern associated with
other elevation alternatives.



Harvest Hill

at The Orchard at New Market

